

# Moon

Enric Batlle, Joan Roig, 1994

Banco sobre murete  
Bench on low wall  
Banc sur muret  
Bank an niedriger Mauer  
1.8 m / 3 m

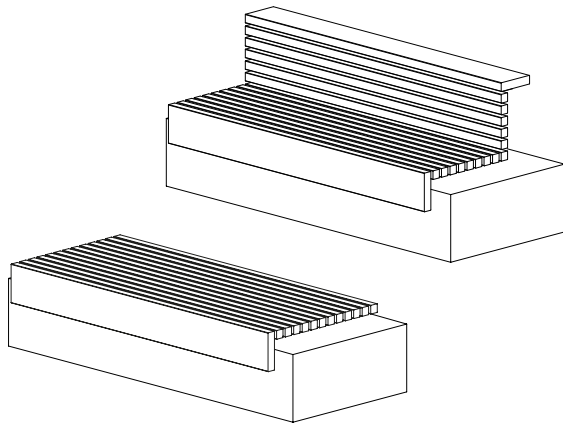

urbidermis.com

[ES]

## MANTENIMIENTO

No requiere mantenimiento, salvo para conservar el color original de la madera.  
Limpiar utilizando productos de limpieza con pH neutro, sin alcohol y no abrasivos.

## GARANTÍA

Este producto está garantizado, según la Ley establecida vigente, a partir de la fecha de factura. La información técnica facilitada por Urbidermis en cuanto a dimensiones, materiales y características, puede ser modificada sin previo aviso.

## INFORMACIÓN

Todas las medidas y características se entienden a título informativo.

Urbidermis se reserva la facultad de modificar, suprimir o ampliar nuestros productos sin previo aviso.

[FR]

## ENTRETIEN

Ne nécessite aucun entretien, si ce n'est pour conserver la couleur d'origine du bois.  
Nettoyer avec des produits de nettoyage au pH neutre, sans alcool et non abrasifs.

## GARANTIE

Ce produit est garanti, selon la loi en vigueur, à compter de la date de la facture. Les informations techniques fournies par Urbidermis sur les dimensions, les matériaux et les caractéristiques peuvent être modifiées sans préavis.

## INFORMATION

Toutes les mesures et caractéristiques sont données à titre d'information.

Urbidermis se réserve le droit de modifier, supprimer ou étendre ses produits sans préavis.

[EN]

## MAINTENANCE

Does not require maintenance, except to preserve the original color of the wood.  
Clean using pH-neutral, alcohol-free, and non-abrasive cleaning products.

## WARRANTY

This product is guaranteed, according to the established Law in force, starting from the date of invoice. The technical information supplied by Urbidermis in relation to dimensions, materials and characteristics may be modified without prior notice.

## INFORMATION

All magnitudes and characteristics are considered for information.

Urbidermis reserves the right to modify, delete or expand our products without notice.

[DE]

## WARTUNG

Benötigt keine Wartung, außer für den Erhalt der Originalfarbe des Holzes.  
Reinigen Sie mit pH-neutralen, alkoholfreien und nicht scheuernden Reinigungsmitteln.

## GARANTIE

Dieses Produkt ist ab dem Kaufdatum und gemäß der geltenden Gesetzgebung von einer Garantie gedeckt. Die von Urbidermis übermittelten technischen Daten bezüglich Größe, Materialien und Eigenschaften können ohne Vorankündigung geändert werden.

## INFORMATION

Alle Maße und Merkmale sind informativ zu verstehen. Urbidermis behält sich das Recht vor, unsere Produkte ohne vorherige Ankündigung zu ändern, zu löschen oder zu erweitern.

[ES] SUMINISTRO  
[EN] SUPPLY  
[FR] APPROVISIONNEMENT  
[DE] BESCHAFFUNG

## Moon 1.8 m

\*x1

Según modelo escogido  
According to the chosen model  
Selon le modèle choisi  
Je nach gewähltem Modell

MOBS+04\*  
(58 kg / 127.9 lb)

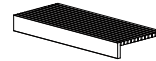

MOB+14\* + MOB02  
(67 kg / 147.7 lb)

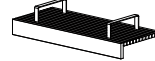

MOBS+14\*  
(88.5 kg / 195.1 lb)

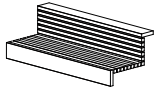

MOB+14\* + MOB03  
(94 kg / 207.2 lb)

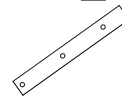
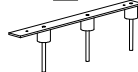
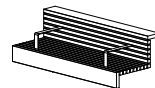

## Moon 3 m

\*x1

Según modelo escogido  
According to the chosen model  
Selon le modèle choisi  
Je nach gewähltem Modell

MOBS+24\*  
(95 kg / 209.4 lb)

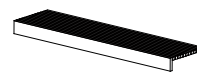

MOBS+24\* + MOB02  
(106 kg / 233.7 lb)

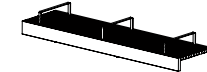

MOBS+34\*  
(145 kg / 319.7 lb)

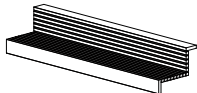

MOBS+34\* + MOB03  
(153 kg / 337.3 lb)

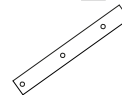
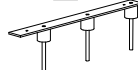
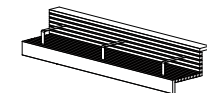

[ES]

No deseche estos productos con otros desechos domésticos; Recíclalos. Para obtener más información sobre el punto de reciclaje más cercano, consulte a su autoridad local de gestión de residuos.

[FR]

Ne jetez pas ces produits avec les autres déchets ménagers - veuillez les recycler. Pour plus d'informations sur le point de recyclage le plus proche, consultez votre autorité locale de gestion des déchets.

[EN]

Do not dispose of these products with other household waste; recycle it. For information on the nearest recycling point, consult your local waste authority.

[DE]

Entsorgen Sie diese Produkte nicht über den Hausmüll, sondern recyceln Sie sie. Weitere Informationen über die nächstgelegene Recyclingstelle erhalten Sie bei Ihrer örtlichen Abfallwirtschaftsbehörde.

# 1

MOBS+O4 / MOBS+24

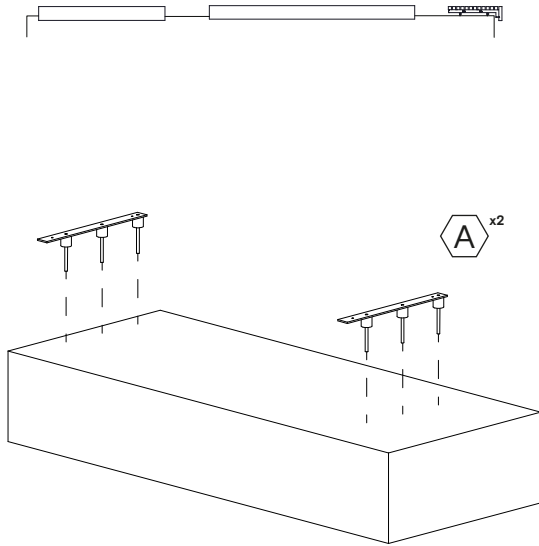

# 2

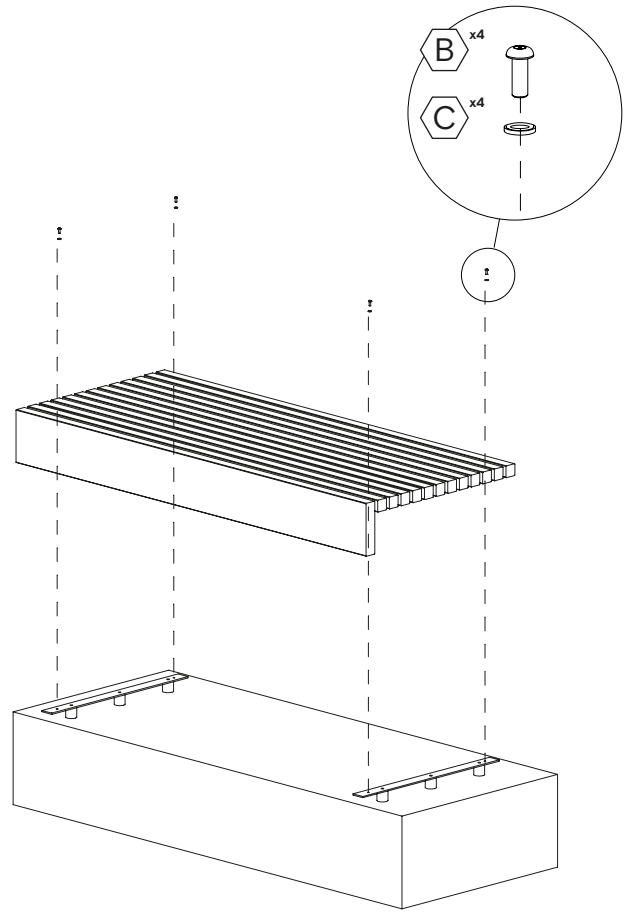

# 3

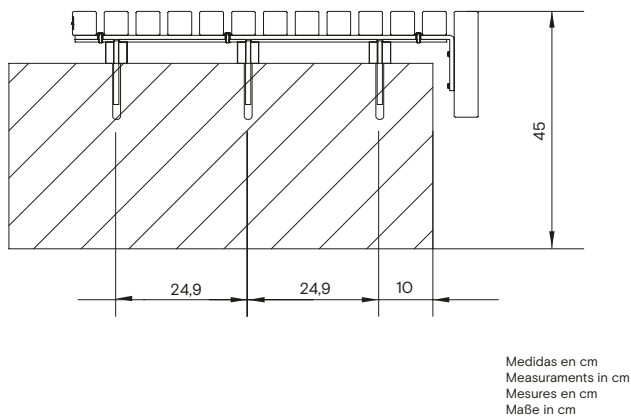

## MOBS+O4

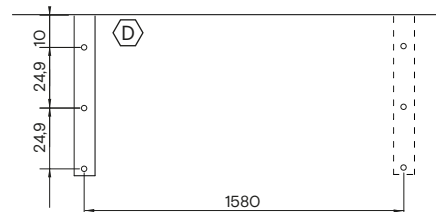

## MOBS+24

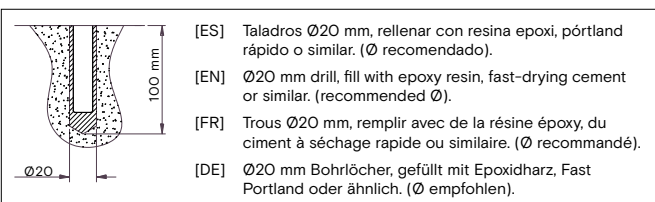
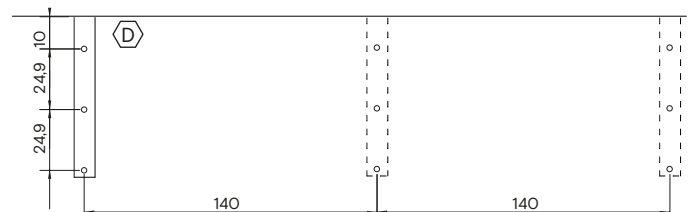

- [ES] Situa la plantilla en el borde del muro para marcar los agujeros de los pernos
- [EN] Place the template on the edge of the wall to mark the bolt holes.
- [FR] Placez le gabarit sur le bord du mur pour marquer les trous des boulons.
- [DE] Die Vorlage am Rand der Mauer auflegen, um die Löcher für die Bolzen zu markieren.

# 1

MOBS+14 / MOBS+34

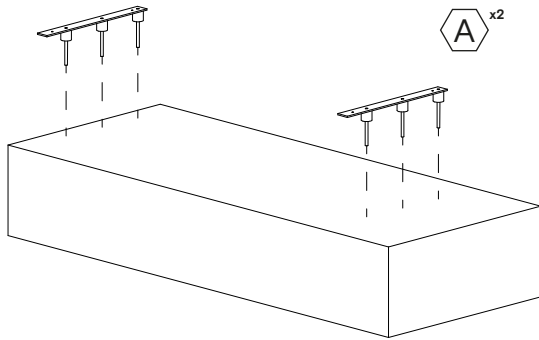

# 2

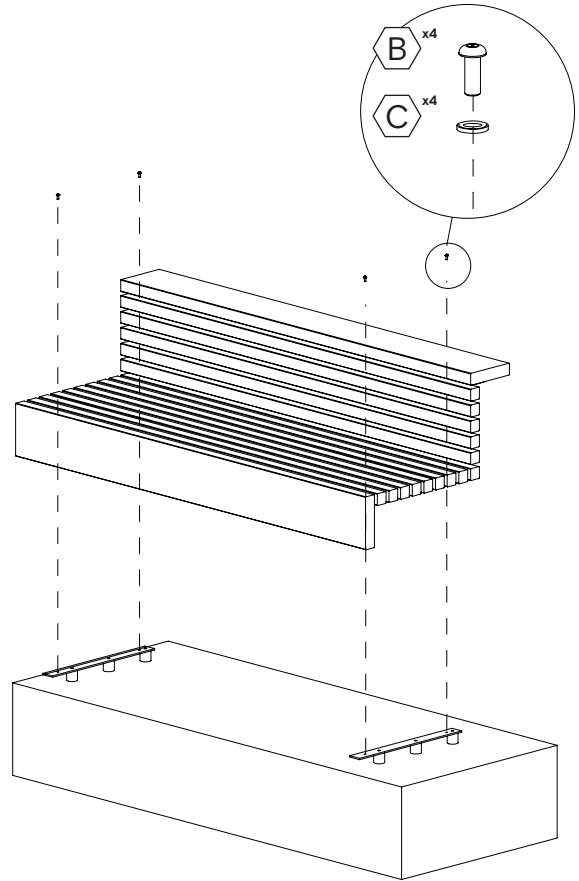

# 3

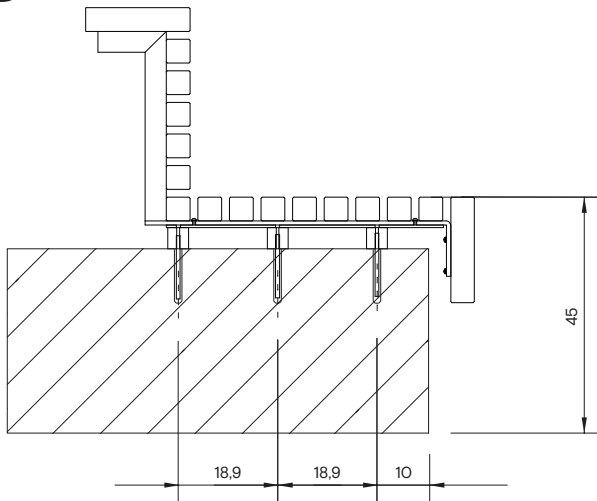

Medidas en cm  
Measurements in cm  
Mesures en cm  
Maße in cm

## MOBS+14



## MOBS+34

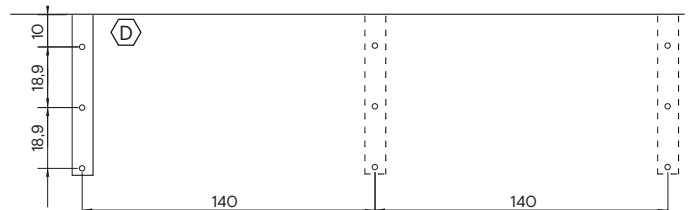

[ES] Taladros Ø20 mm, rellenar con resina epoxi, pórtland rápido o similar. (Ø recomendado).

[EN] Ø20 mm drill, fill with epoxy resin, fast-drying cement or similar. (recommended Ø).

[FR] Trous Ø20 mm, remplir avec de la résine époxy, du ciment à séchage rapide ou similaire. (Ø recommandé).

[DE] Ø20 mm Bohrlöcher, gefüllt mit Epoxidharz, Fast Portland oder ähnlich. (Ø empfohlen).

- [ES] Situa la plantilla en el borde del muro para marcar los agujeros de los pernos
- [EN] Place the template on the edge of the wall to mark the bolt holes.
- [FR] Placez le gabarit sur le bord du mur pour marquer les trous des boulons.
- [DE] Die Vorlage am Rand der Mauer auflegen, um die Löcher für die Bolzen zu markieren.